



Ip morgan flipper *user manual*



Notes, Notices and Cautions



TIP: A tip give you information that can help you make better use of your flipper.



NOTE: A note indicates either potential damage to ceiling or projector and tells you how to avoid the problem.



CAUTION: A caution indicates a potential for property damage, personal injury or death.

Information in this document is subject to change without notice.

© 2002-2006 Herma Technologies. All rights reserved.

Reproduction in any manner whatsoever without permission of Herma Technologies is strictly forbidden.

Trademarks used in this text: *Herma*, the Herma Logo, and LP Morgan logo are registered trademarks of Herma Technologies.

Other trademarks and trade names may be used in this document to refer to either the entities claiming the marks and names or their product. Herma Technologies disclaims interest in trademarks and trade names other than its own.

Table of contents



Important information

Precaution	4
To the owner	5
Unpacking	6
Part Names and Dimensions	8



Installation

Mechanical Installation	12
Ceiling opening	13
Ceiling Space	14



Electrical Installation

Wiring Diagram	17
----------------	----



Projector Installation

Extra Adjustment	20
Cable Management	21
MultiFlip	22
Dustcover Fitting	24

Accessories



Troubleshooting



Warranty

Precautions

ATTENTION: Please read all of these instructions before you operate your Flipper for the first time. Save these instructions for further reference.

 **Never operate the Flipper while the projector is still powered!**

On Safety

Check that the operating voltage of your unit is identical with the voltage of your local power supply. If voltage adaptation is required, consult with a qualified electrician.

Should liquid or solid objects fall into the unit, unplug and have it checked by qualified personnel before operating it further.

To disconnect the cord, pull it out by the plug. Never pull the cord itself.

The power supply should be near the unit and easily accessible.

Do not place your hand or other objects near the trapdoor during operation.

The Skyhook Projector Mount must be used for installation with the Flipper.

On Cleaning

To keep the unit looking new and clean a dust cover is supplied. If cleaning is necessary use a soft cloth and mild detergent solution. Never use strong solvents, such as thinners, benzene, or abrasive cleaners.



To the owner

Congratulations on purchasing an **Ip morgan** Flipper. This innovative projector mounting system is a novel and secure way to mount your projector out of sight when not in use, giving you maximum enjoyment and a truly cinematic experience.

Since the Flipper was first released in 2004, we have added some new features that makes the Flipper even more versatile:

- Multiflip - for installation at any angle (even in a wall!)
- Stall Sensing - for installtion in a tabletop/bench. Current sensor detects an obstruction and will stop the unit for added safety.

Please take a moment to review this manual, as it will ensure you many years of trouble-free service from your new Flipper.



Unpacking the Flipper

When unpacking the Flipper, please handle all parts with care.



Do not destroy the folded inner box when unpacking, as it is the dustcover for this unit!

Important
information

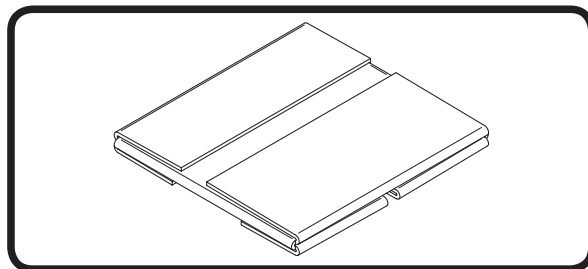
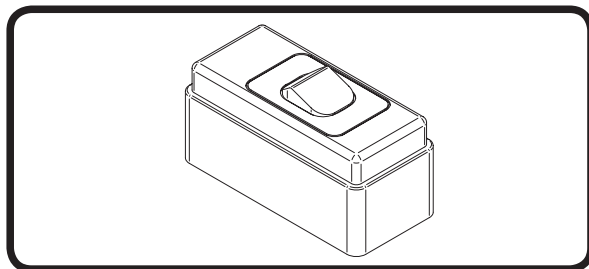
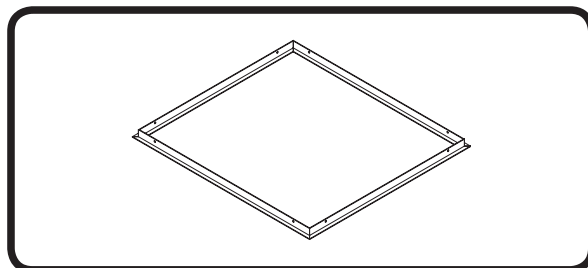
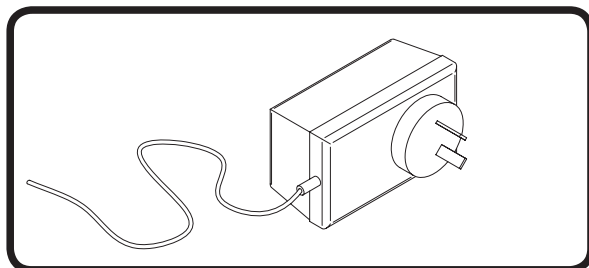
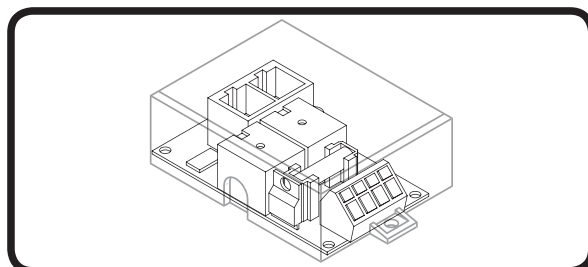
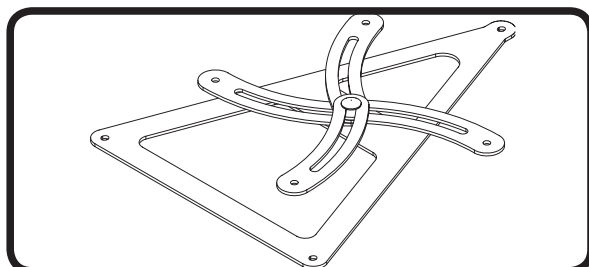
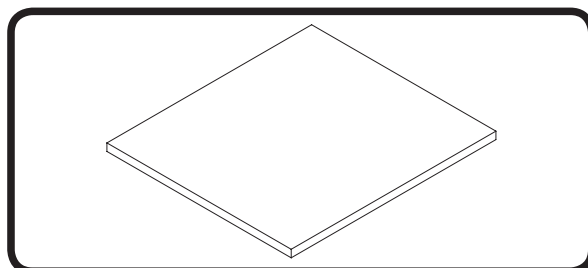
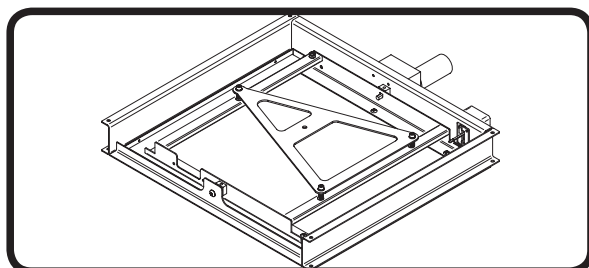



1	2	1. Powdercoated steel frame and pivot assembly
3	4	2. Undercoated timber panel (affixed)
5	6	3. LP Morgan Skyhook Projector Mount System (including mounting bolts and spacers)
7	8	4. Control Unit
		5. 12V Power Supply
		6. Aluminium Ceiling Trim
		7. Wall Switch and Architrave Mount
		8. Cardboard Dustcover

Dimensions

The next few pages give you the major dimensions and part names of the flipper, so you can familiarise yourself with the product.

Top View, Closed Position

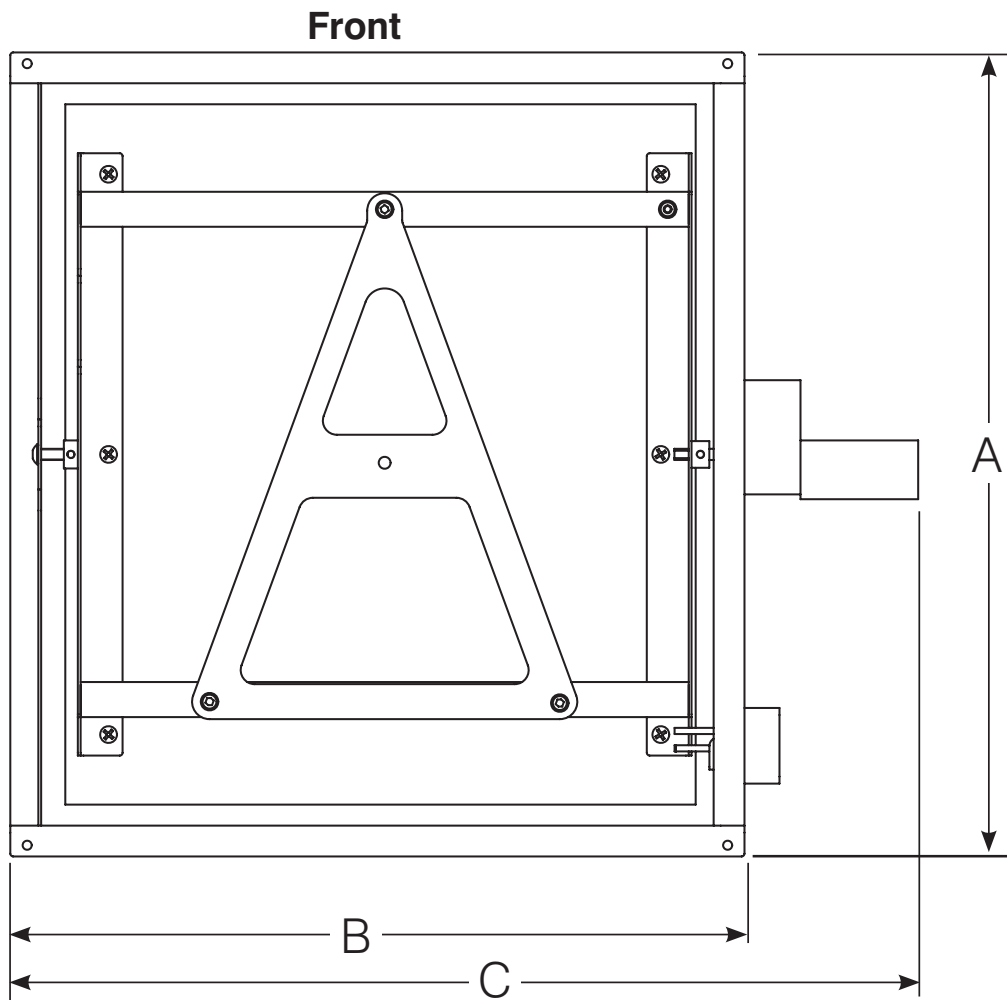

Back View, Closed Position

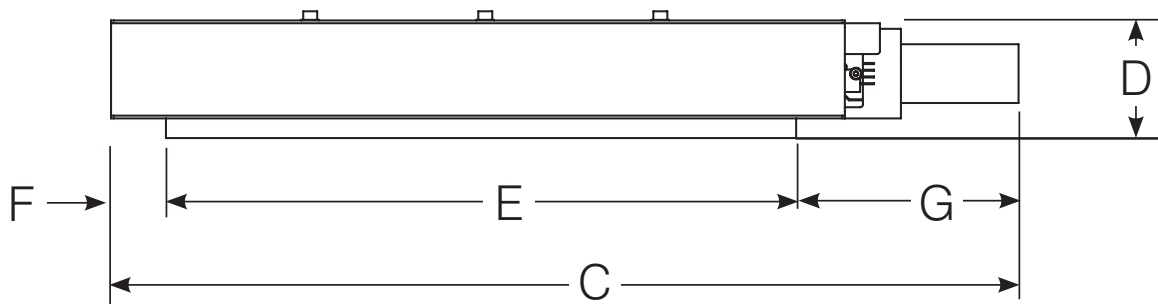

Dimensions

Dimension	Name	Std Flipper	Lrg Flipper
A	Overall Length	575	675
B	Frame Width	515	615
C	Overall Width	670	770
D	Closed Height	84	84
E	Face Panel Width	450	550
F	LHS Panel Offset	40	40
G	RHS Panel Offset	180	180
H	Face Panel Length	500	600
I	Rear Offset	37.5	37.5
J	Front Offset	37.5	37.5
K	Operating Height	350	400

Important
information

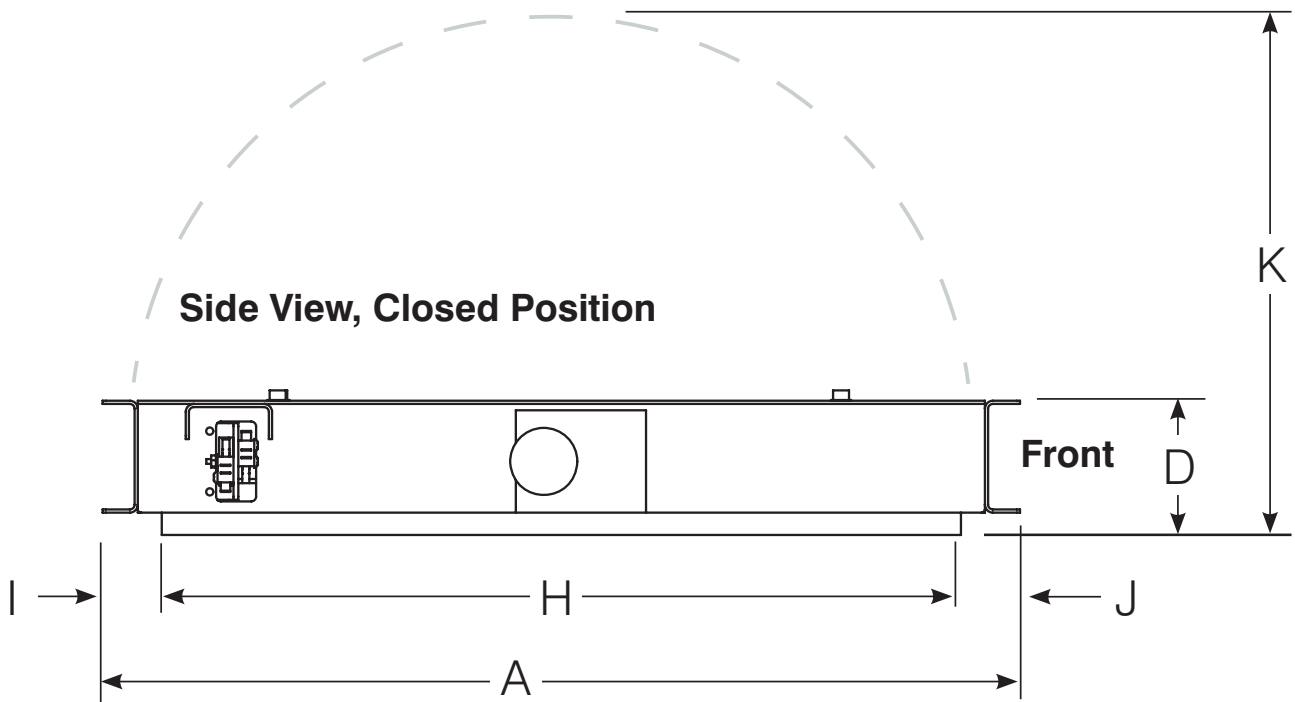

Part Names

Important
information

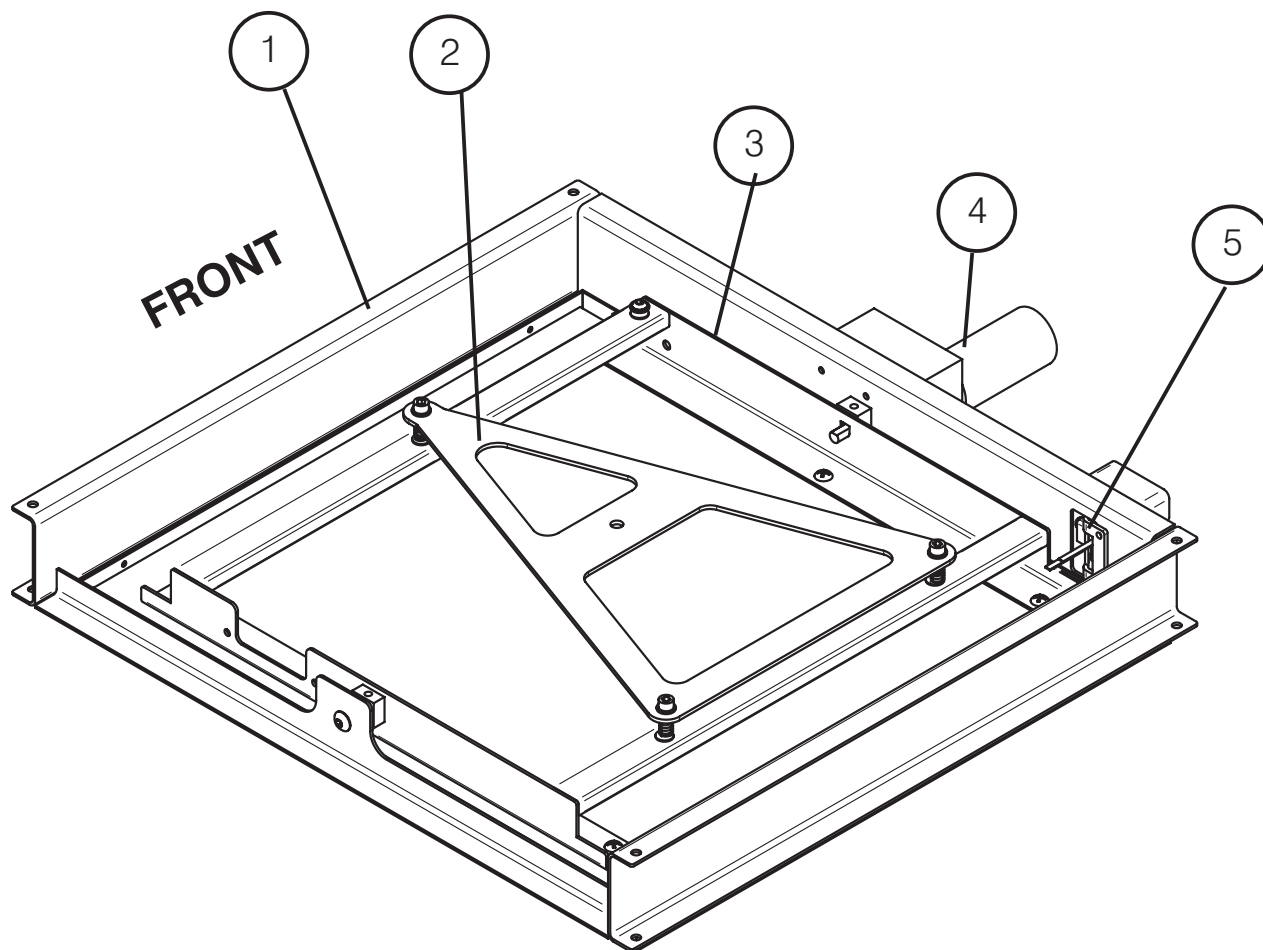

1. Flipper Frame
2. Skyhook Plate
3. Pivot Frame
4. Motor
5. Limit Switches

Orientation

In use

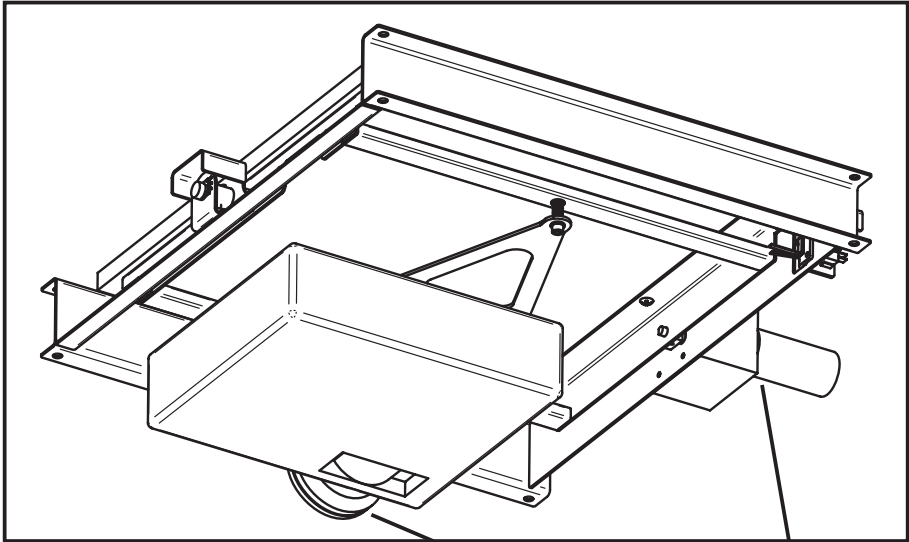

Note motor position and projector orientation

Not in use

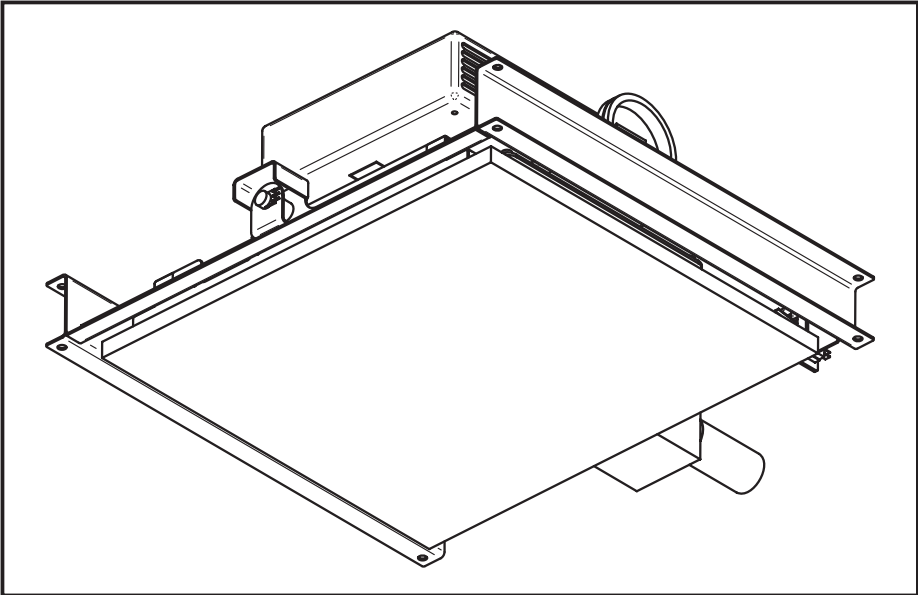

Important information 

Mechanical Installation

The Flipper may be installed through its own hole if required.

The first crucial step, like any projector installation, is to determine where to put the Flipper in the ceiling. The Flipper should be installed so that the projector lens is centered horizontally to the screen, and the distance from the screen depends on the projector's throw distance.

Work out the maximum and minimum throw distances for the projector and place the Flipper somewhere in between. It is better for the projector to be closer to the screen, but don't place it at an extreme—leave yourself some room to adjust the zoom in either direction.

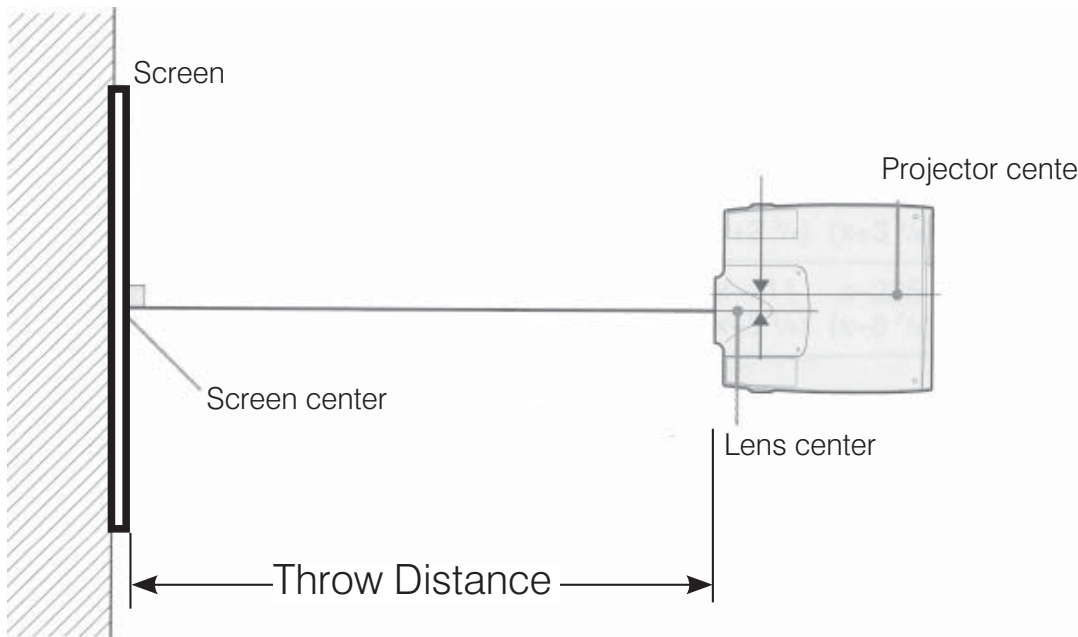

Note: when aligning the Flipper make sure that the projector **lens** is centered on the screen, which is not necessarily the projector center.

Ceiling opening

The Flipper was designed by an installer, with the installer in mind. The face panel that is supplied is 18mm undercoated MDF, and is easily removed via 6 screws.

We recommend that you remove and paint this panel before fixing the Flipper in the ceiling.

In the case of a non-plasterboard ceiling, you may choose to fabricate your own ceiling panel (eg from the same timber/material as the ceiling itself) to match.

The Ceiling trim we supply will leave a 2mm clearance on all sides of this face panel.

If you choose not to use this ceiling trim, you should be aware that *you will need to allow more clearance at the front and back of the panel*, because the trajectory traced by the ceiling panel is actually wider than the ceiling trim.

For a Standard Flipper:

	Length	Width
Face Panel	500	450
Cutout required, if NOT using the supplied trim	508	454
Cutout required, if using the supplied trim	528	478

For a Large Flipper:

	Length	Width
Face Panel	600	550
Cutout required, if NOT using the supplied trim	608	554
Cutout required, if using the supplied trim	628	578



Ceiling Space

The following diagrams show the position of the ceiling cutout in relation to the Flipper frame, the space required above the ceiling, and the mounting hole positions.

The Flipper has been designed to be compatible with just about any installation situation. You should be able to adapt the Flipper to suit your specific installation requirements.

The Flipper frame is designed to sit 12.5mm above the ceiling—that is, it virtually rests on the plaster!

Where possible, install the Flipper in such a way that you can microadjust the height so you can get it exactly flush with the ceiling. eg - suspended from threaded rod.

Mechanical
Installation

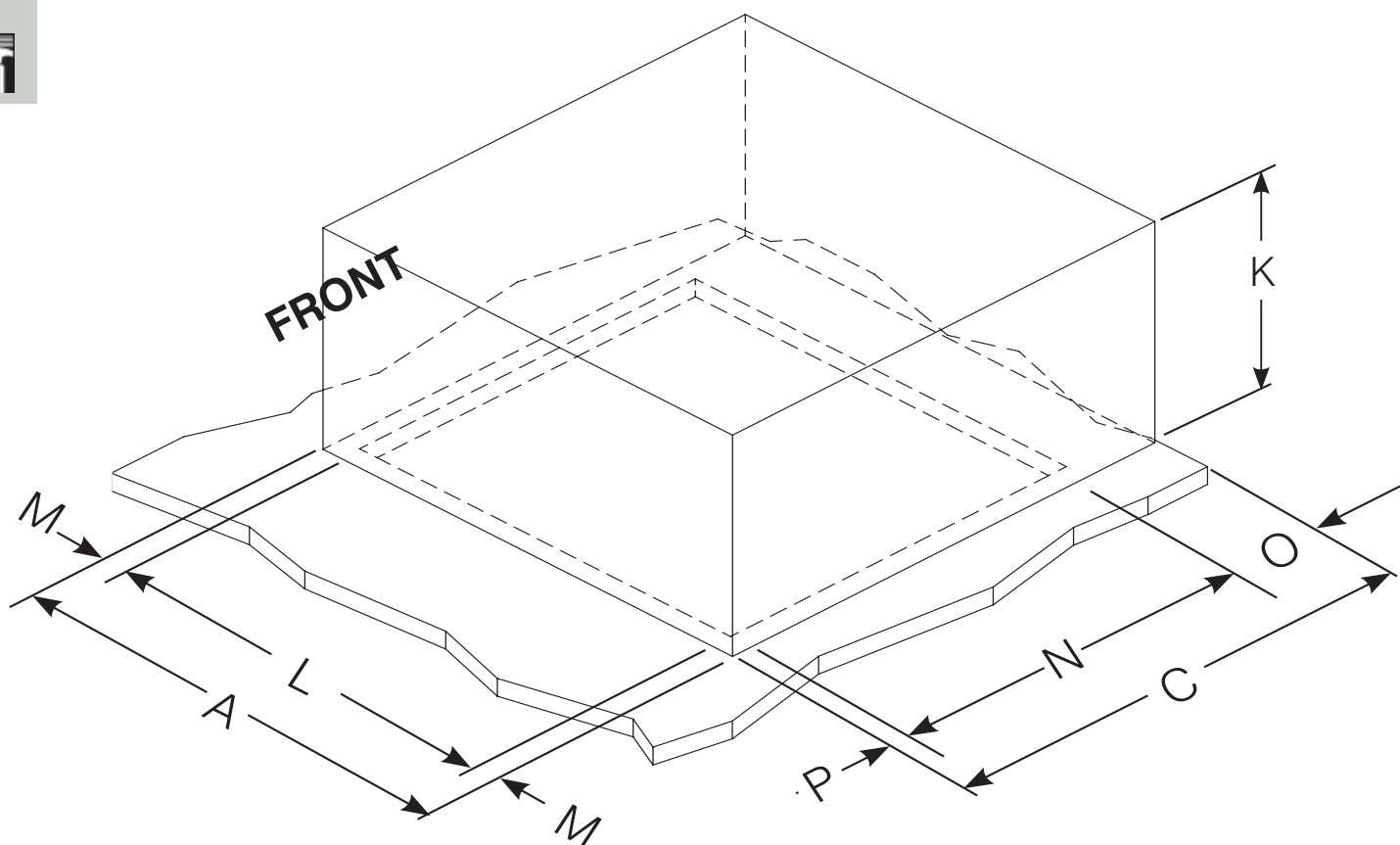



Dimension	Name	Std Flipper	Lrg Flipper
A	Overall Length	575	675
C	Overall Width	670	770
K	Operating Height	350	400
L	Cutout Length	528	628
M	Front & Back Offset	23.5	23.5
N	Cutout Width	478	578
P	Left Offset	26	26
O	Right Offset	166	166
Q	Widthways Hole Spacing	500	600
R	Lengthways Hole Spacing	558	658
S	Hole Offset	8	8
T	Right Hole Offset	162	162

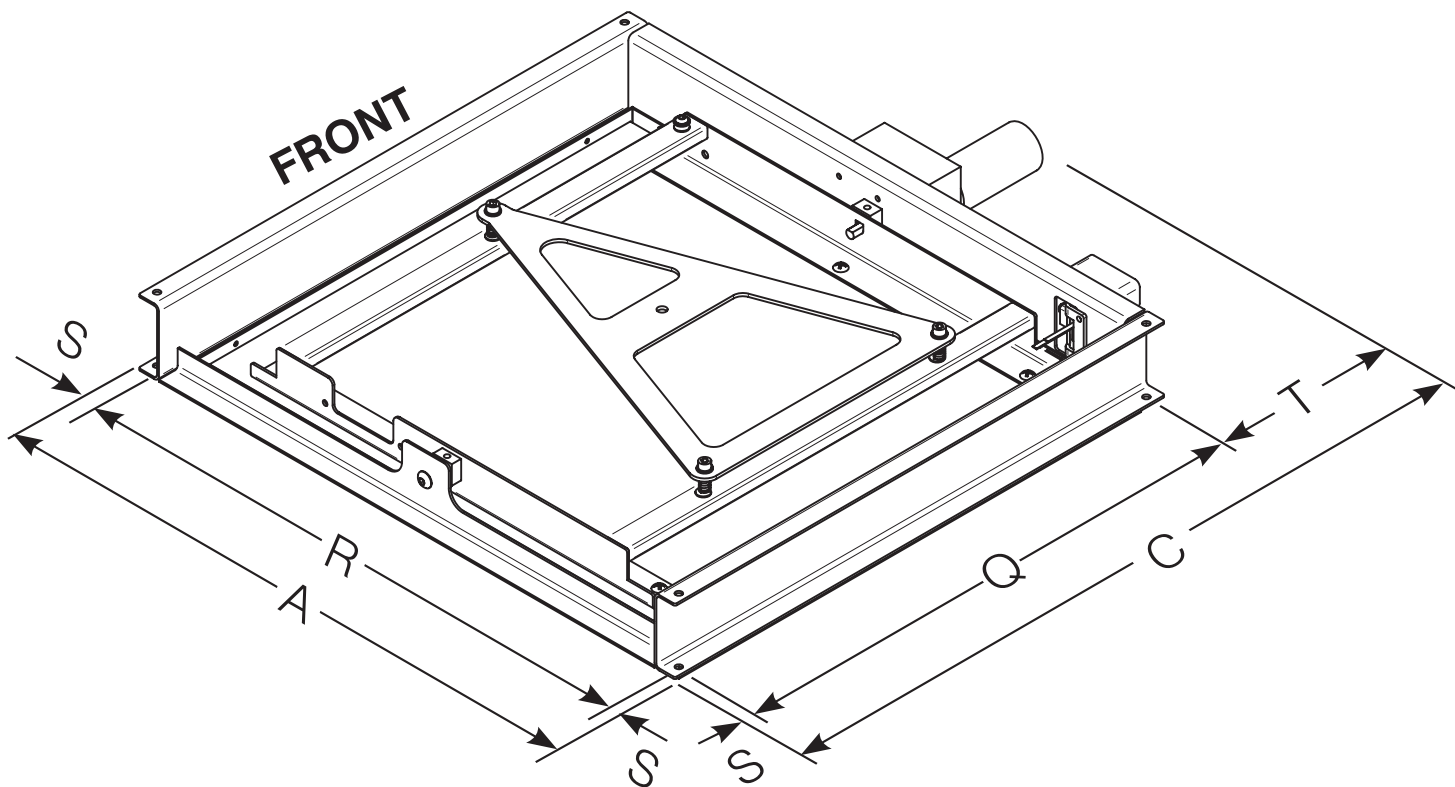

Electrical Installation

⚠ Do Not, under any circumstances, connect 240 VAC to any of these terminals!

The Flipper is supplied with a 12V control unit that can be operated by either close contacts or the supplied wall switch.

You do not need to be a qualified electrician to wire the Flipper, as all circuiting is 12V, however Herma will not accept responsibility for damage incurred by faulty or incorrect wiring.

The motor, limit switches and power supply are supplied prewired into the control box. If you need to disconnect them, use the following wiring diagram very carefully. You could damage your Flipper permanently if you wire it incorrectly!

Electrical
Installation

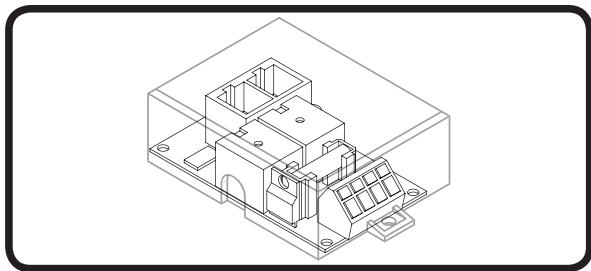

Control Unit

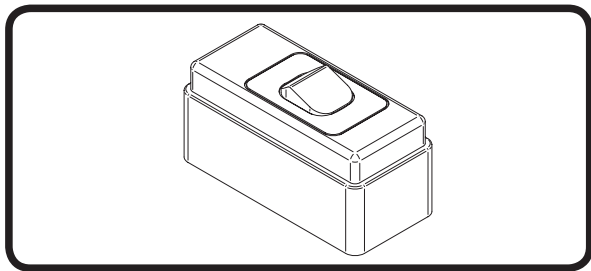

Wall Switch

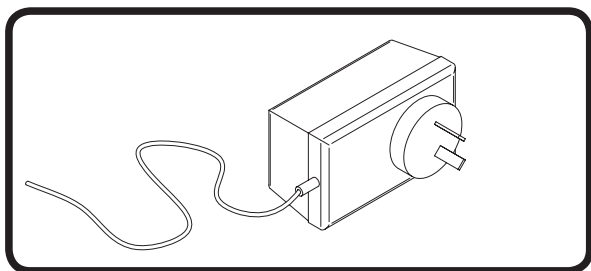

12V Power Supply

Wiring Diagram

We supply these units pre-programmed to operate via a maintained SPST switch (a single throw relay). The supplied switch should be connected to the “Up” and “Common” terminals ONLY.

Should you wish to use a different sort of switching method (eg SPDT), you can easily program the device to do so. However, you will need a receiver eye and special programming remote (available as our Installer’s Kit - LPM43INSKIT)

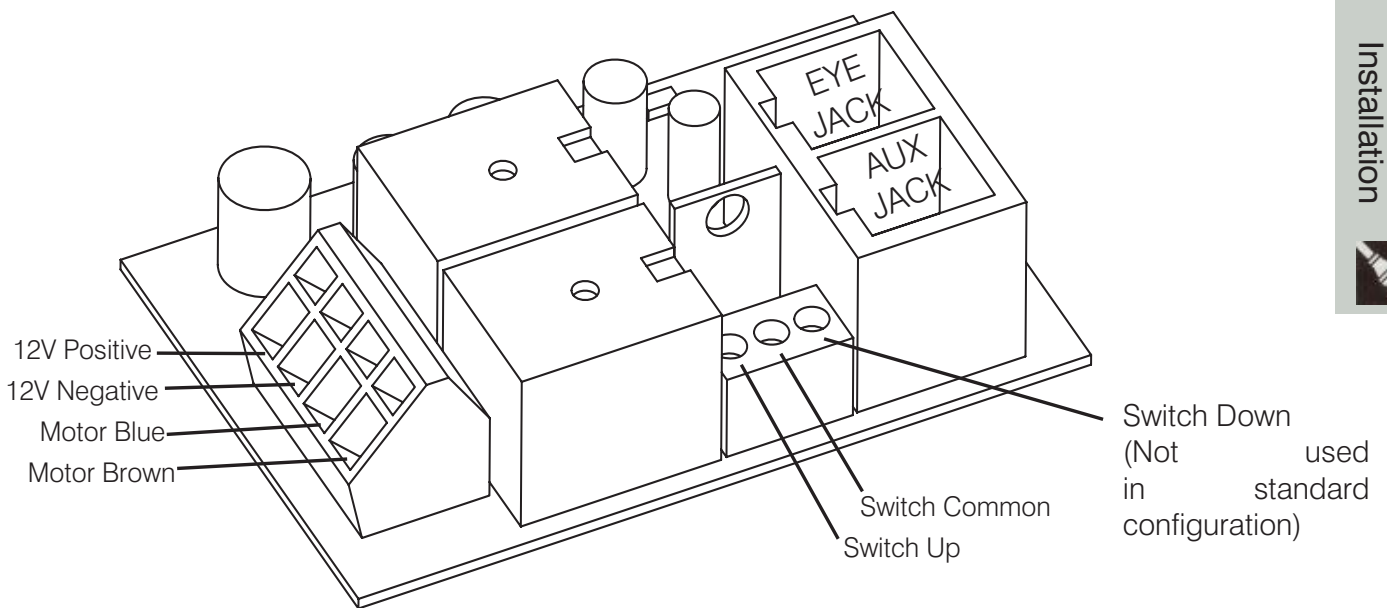

Use a small flat screwdriver to prise open the motor and mains terminals



Stall Sensing

These control units have an in-built stall sensor which is a necessary feature if you are installing a Flipper into a tabletop.

To activate the stall feature you need to purchase a programmer’s kit (LPM43INSKIT) has included detailed instructions on setting a calibrating the current threshold.

Contact Herma if you want further information on stall settings.

Projector Installation

The Flipper uses the Ip morgan Skyhook projector mount system.

The parts kit contains:

- 4 x long skyhook arms
- 2 x short skyhook arms.
- 4 x M4, 4 x M5 & 4 x M6 mounting bolts
- 4 x springs

Determine which size mounting bolts suit your projector, and set others aside. They are no longer required.

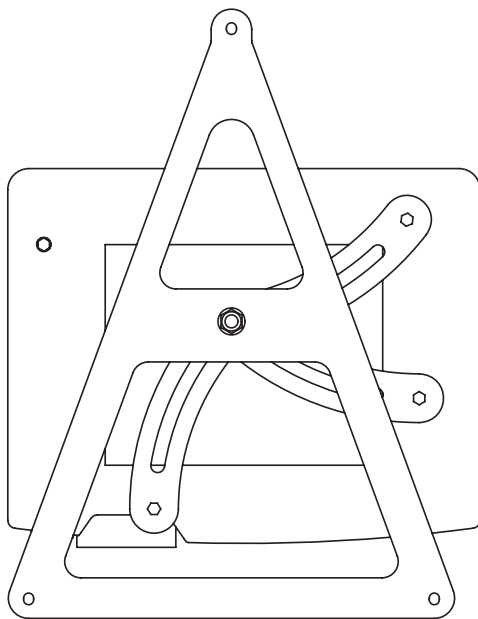
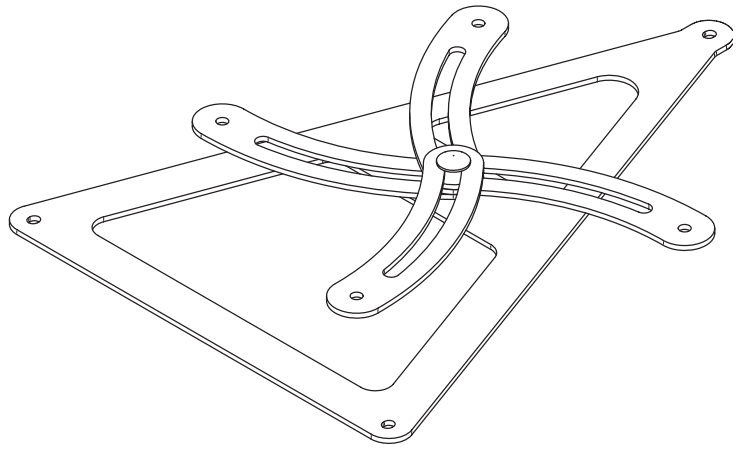

If your projector has only 3 mounting holes, remove one of the adjustable arms. Undo the M8 Nyloc nut, remove an arm, and replace the nut.

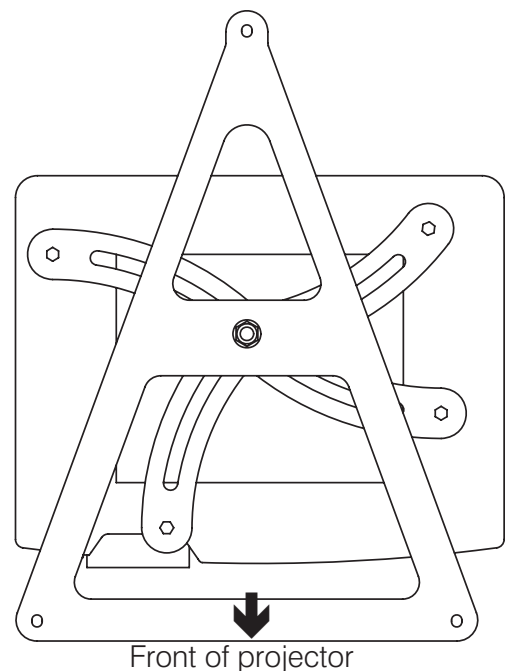

Before connecting the Skyhook, spread out the arms so each end is over one of the mounting holes. If you feel it necessary, this is an appropriate time to remove 1 or 2 of the short arms and replace with the supplied optional longer arms .



Connect Skyhook to Projector. Fit the springs between the arms and the projector, and tighten the mounting bolts so that the projector is parallel to the triangular plate.

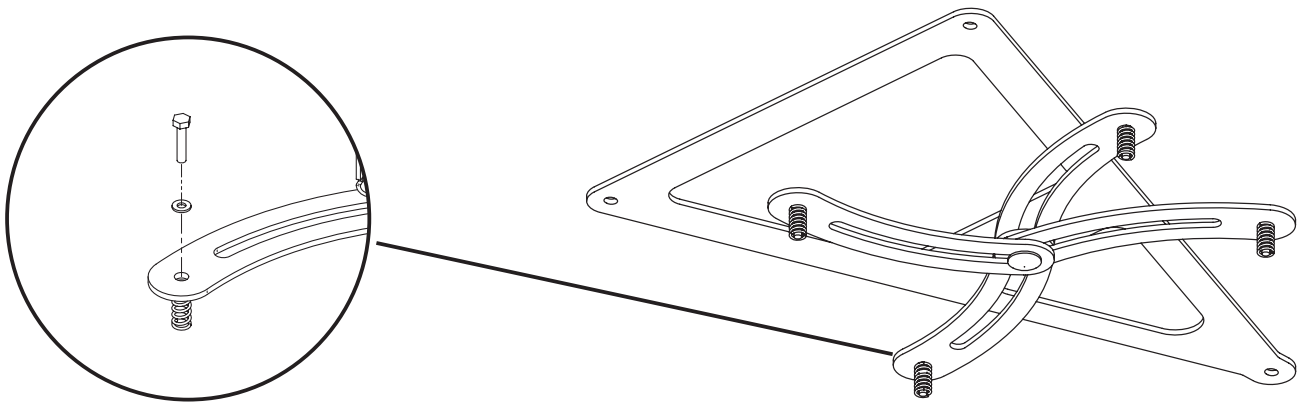

Move the position of the triangular plate over the centre of the projector, with the edge with the 2 holes towards the front.

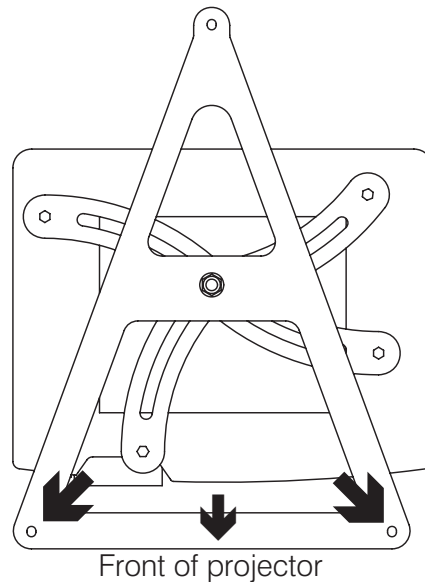

Tighten the mounting bolts. The projector and skyhook system is ready to be inserted into the Flipper.

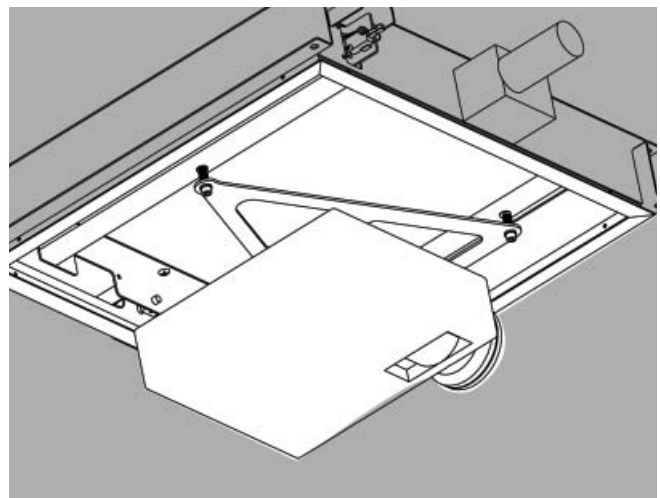

Flipper Skyhook unit

- ➡ First ensure that the Flipper is operating correctly, and that the projector cables are properly secured.

Open the Flipper and bolt the triangular projector plate to the underside of the Flipper using the supplied M6 bolts and springs.

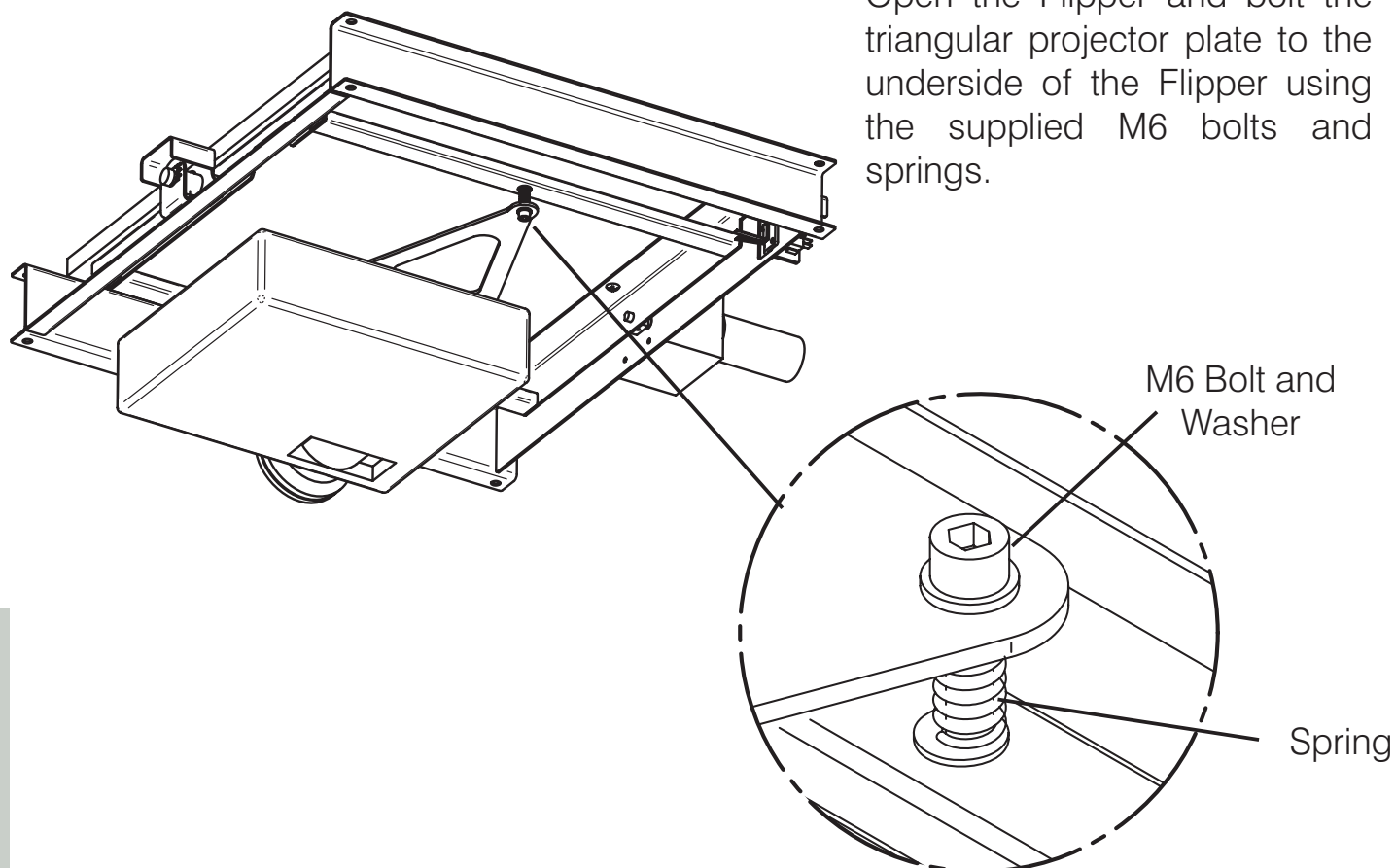

Detail: M6 bolts and Spring

These bolts will also give you Yaw and Tilt adjustment to align your image on the screen, while the the center M8 bolt provides Pan adjustment. The springs will ensure that the projector is held still during motion. Do not install the projector plate without springs.

Extra Adjustment

You can fine tune the open and closed positions of the Flipper by adjusting the angle of the two limit arms on each side of the pivot frame (see page 10 for part names).

These arms hit the limit switches in the closed and open positions.



Cable Management

 Because every projector has a different point of access for its mounting points and cable, the Flipper provides an exit opening on the side of the pivot frame for the projector cables. There are two holes near this cutout that you may use to tie off the cables, so that they are firmly secured.

Ensure that you leave enough slack for the cables, so that the cable will not interfere with the motion of the unit.

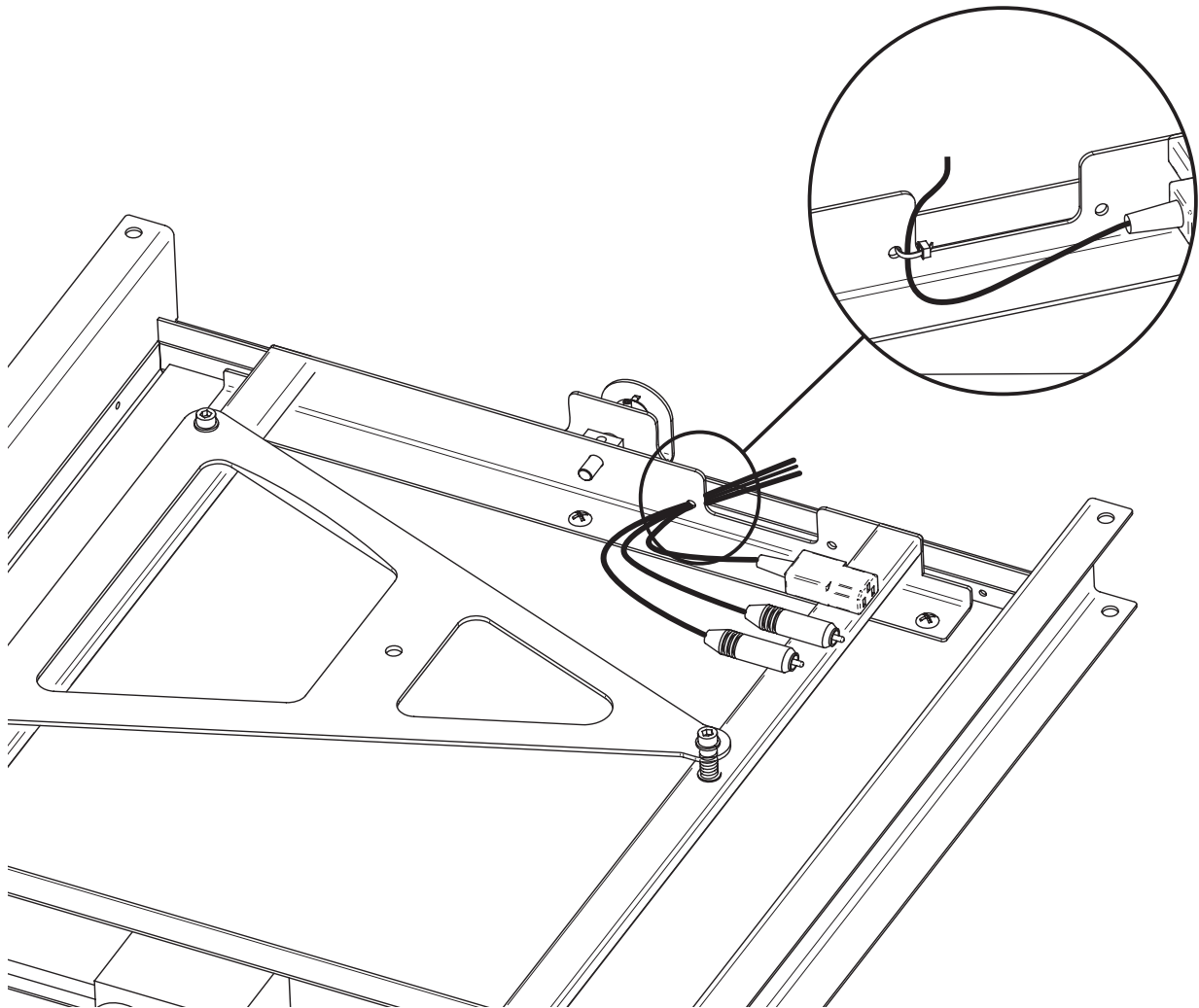

Cable management



Multiflip

The multiflip bracket is an accessory that allow you to install the Flipper into an angled ceiling or even a wall.

You do not need to use the multiflip if installing into a horizontal ceiling or tabletop.

1. Remove one of the limit arms (the one that sets the open position) and attach it to the multiflip bracket as shown, using the supplied M6 x 10 Bolt.

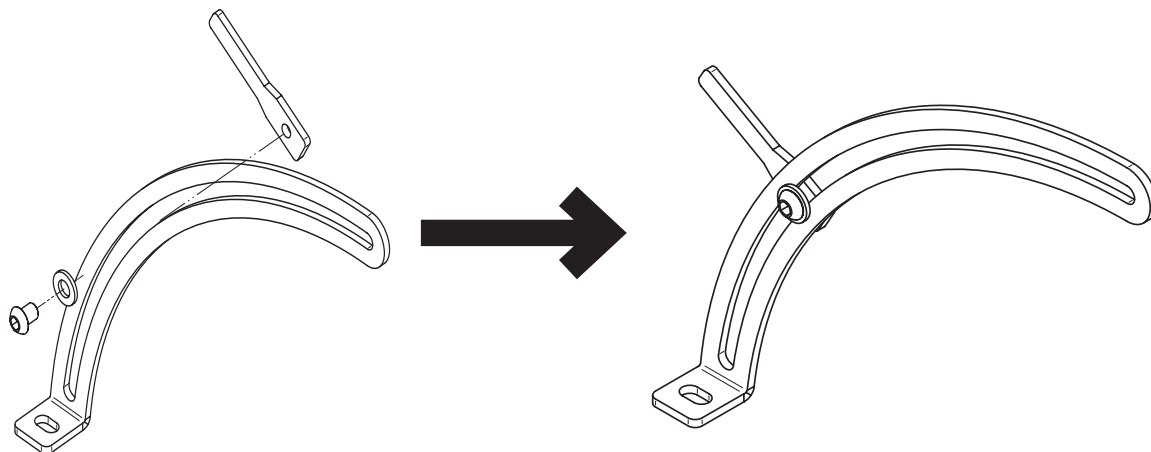

2. Attach the multiflip bracket to the Flipper as shown, using another of the M6 x 10 Bolts.

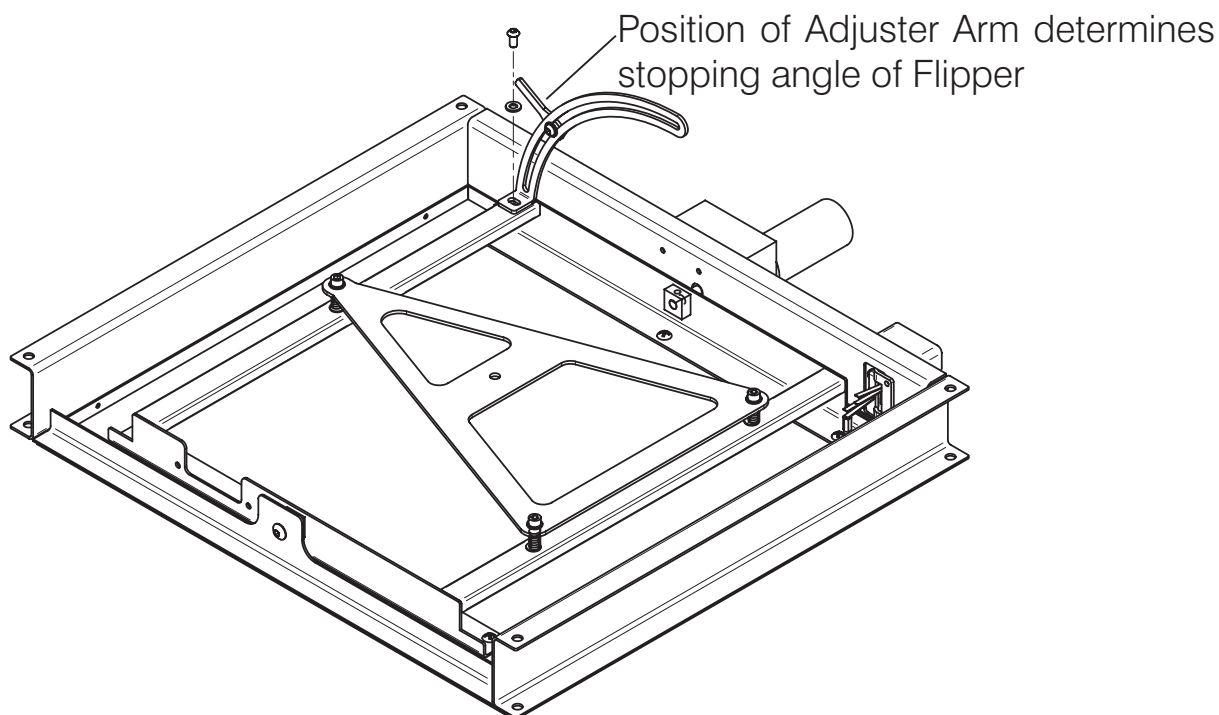

Multiflip

3. Adjust the position of the Limit Arm to give you the desired stopping angle

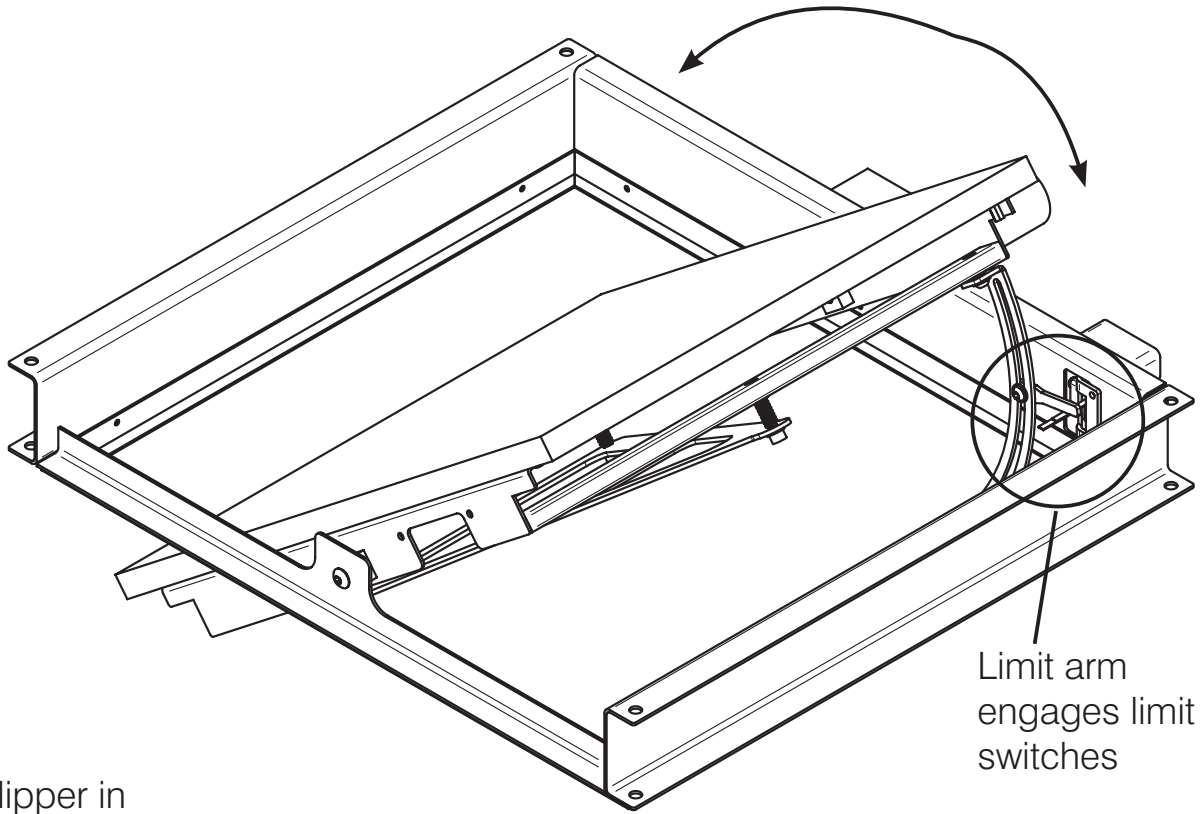

Flipper in Angled Ceiling

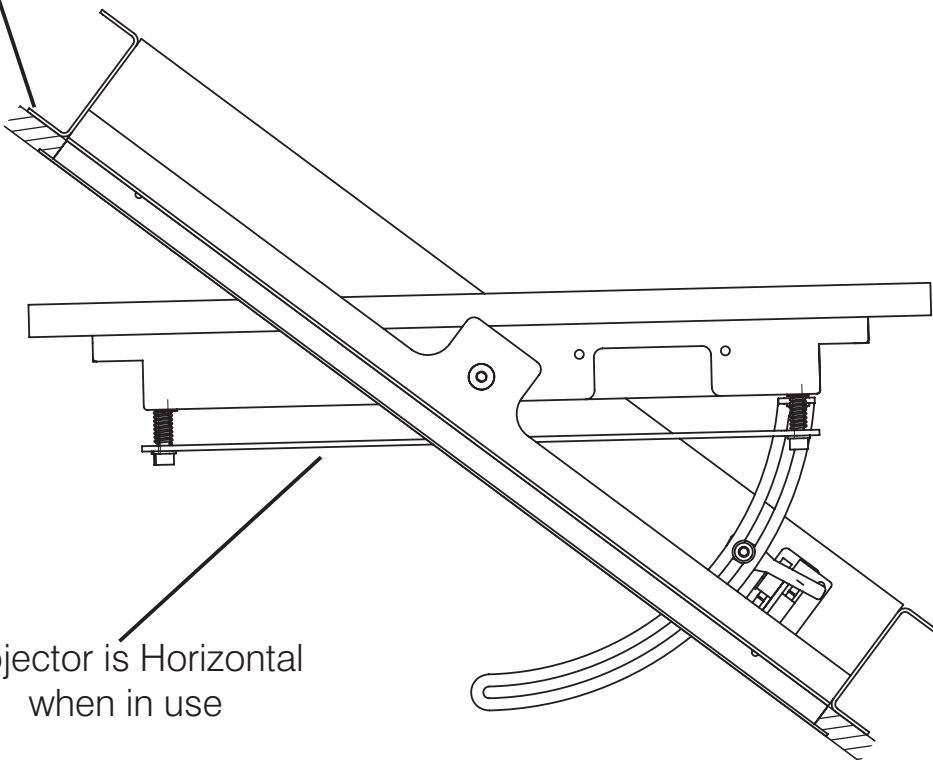

Dust Cover Fitting

We supply a folded cardboard box as a dustcover for the Flipper. Cardboard is much more environmentally friendly than plastic, cheaper and is easily modified to suit your specific installation.

Note: You may need to cut the dustcover to fit around/over bearers in the ceiling.

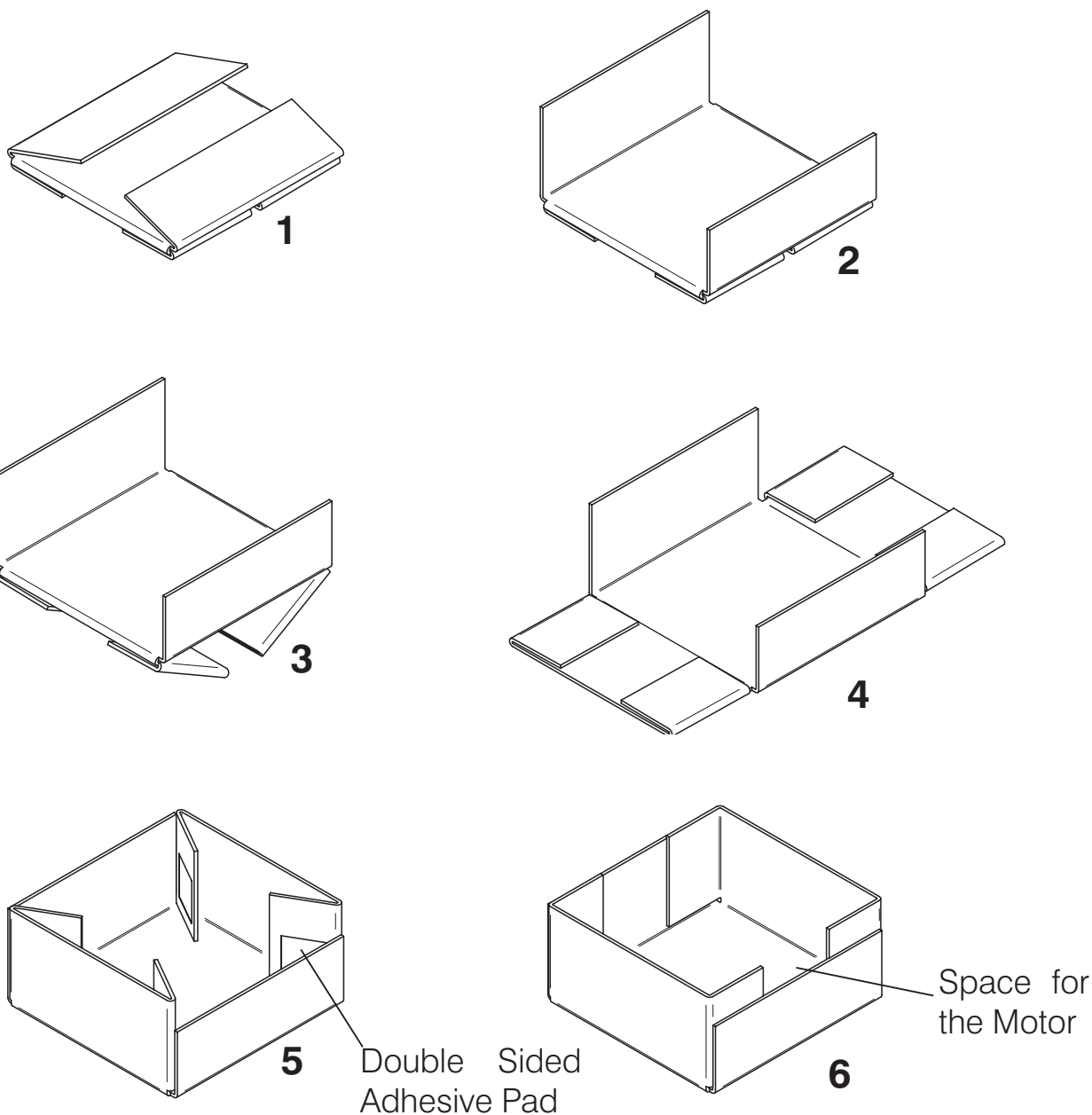

Accessories

The following accessories are also available from **LP Morgan**. Contact your local retailer for pricing information.

Triggering From Projector:

HER20HD12V: 12 volt trigger unit for projectors **with** a 12 volt trigger output.

- Often used also with **LPM43SCR12V**: Screen 12V Trigger

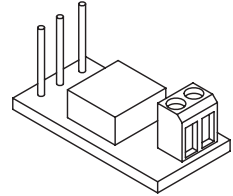

LPM48HDSCRTRIG: Trigger Unit for Projectors **without** a 12 Volt Trigger

- Uses current sensing to detect when the projector is on.
- Triggers a screen as well.
- Includes an IR repeater kit

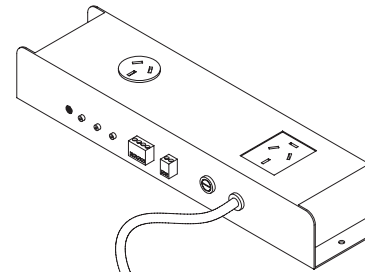

Infra Red Remote Control:

HER20HDIRKIT: Infra Red remote control and receiver

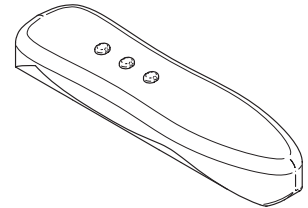

Radio Frequency Remote Control:

HER20HDRFKIT: Radio Frequency remote control and receiver

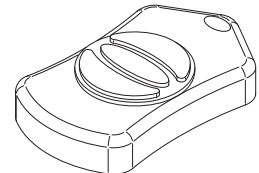

RS232 Integration:

LPM43MULTI: RS232 Interface for both Projector Mount and Screen Controls.

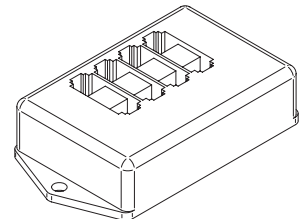

Maintenance and Troubleshooting

The unit has stopped working and won't go up or down:

1. Check that all the terminations are secure, that the power supply is plugged in and that the cables are free from damage.
2. A light on the power supply indicates power - if it is off, then the power supply may be damaged.
3. Open the black plastic enclosure to expose the control board. Switch the power off and on. You will see a LED flash on the circuit board which indicates power, and that the circuit board is operating correctly.
4. Close the Switch "Up" and "Common" terminals on the control board (refer to page 17 for a wiring diagram). If the unit does not move, but you hear a "clicking" sound then the motor may be damaged. Contact Herma for advice.

If you have integrated the Flipper into a control system (eg Projector triggering, IR repeating, Crestron, AMX, etc) then the problem is most likely with the control system! Check that the right signal is getting to the Flipper. Use the wall switch (close the Switch "Up" and "Common" terminals) to test the unit.

If it still doesn't work, Contact Herma for advice.

The projector cables get jammed in the pivot frame as it rotates:

Check that the cutout for the projector cable is on the right side – NOT THE MOTOR SIDE.

You may have it installed upside down! Check the diagram on page 10 and take care of the motor and projector orientation.

The unit may be turning the wrong way – if this is so, it will damage the microswitches as it turns. Contact Herma for advice.

The Face panel is not squared/centred in the trim:

Loosen the 6 screws (but don't undo!), and you will be able to adjust the position of the face panel slightly (by about 2mm)– since the holes the screws go through are a 2mm larger than the screws.



Warranty Information

Customers must fill out the online warranty form, or the warranty card included with the product and post it back to Herma at the reply paid address shown on the back cover in order to qualify for the manufacturer's warranty.

www.herma.com.au/warranty

The warranty covers defects in workmanship and materials, provided this product has been installed in a normal environment and maintained according to the written instructions. Herma warrants the product against loss of usefulness, discolouration or deterioration of optical quality within the warranty period as a result of manufacturing or material defects. This warranty applies only within Australia.

CONDITIONS –

Herma will repair or replace, with the least possible delay, any defective equipment. Any equipment replaced pursuant to the terms of this warranty shall be retained by Herma

All costs related to installation and re-installation of the Herma equipment covered by this warranty are not the responsibility of Herma Technologies. Herma will not be responsible for any consequential damages during or following installation procedures.

The user is responsible for any freight costs relating to repair or replacement. Equipment must be returned to Herma in suitable packing to prevent damage in transit. Herma will not accept any responsibility for damage to the equipment caused by inadequate or unsuitable packing, or for any damage howsoever caused whilst the goods are in transit.

Herma Technologies shall not be liable for any injury, loss or damage, direct or consequential, arising out of the use of, misuse of, or inability to use, the equipment.

This Warranty does not cover any equipment which has been subjected to misuse, abuse, neglect, accidental or intentional damage, improper voltage or any alteration which affects the reliability or performance of the equipment not attributable to faulty manufacture, parts or labour and without limiting the generality of the foregoing shall not apply where the defect arose as the result of the following circumstances:

This Warranty does not cover any equipment where usage, adaptation or installation (including wiring of electrical connections) are not in accordance with our written installation and operating instructions.

Warranty Period: 2 years



Your **lp morgan** Retailer is able to provide information on your product. If we can be of any further help, please contact us.

HERMA



Factory 4a, 6 Albert Street Preston Vic 3072

Phone: +61 3 9480 6233 Fax: +61 3 9480 6533

Email: info@herma.com.au

Web: www.herma.com.au | www.lpmorgan.com.au